

Printed copies are for reference only.

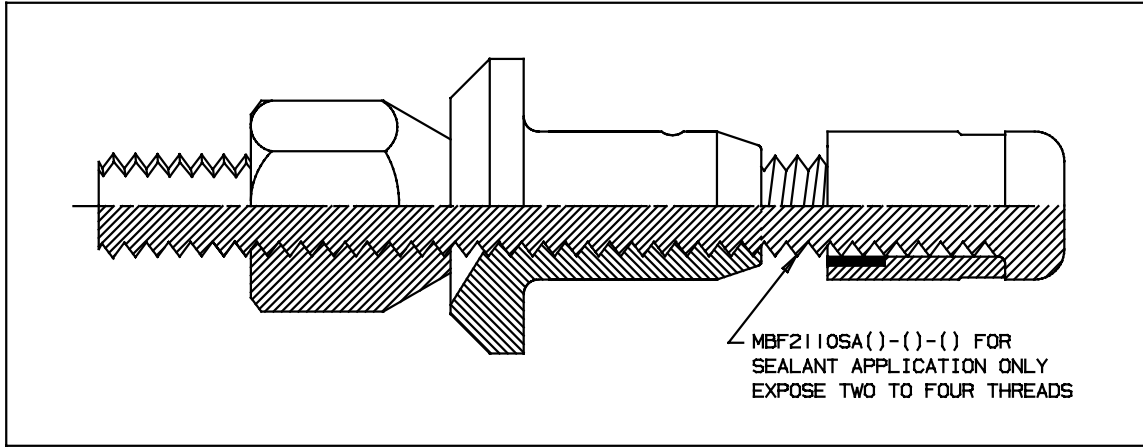
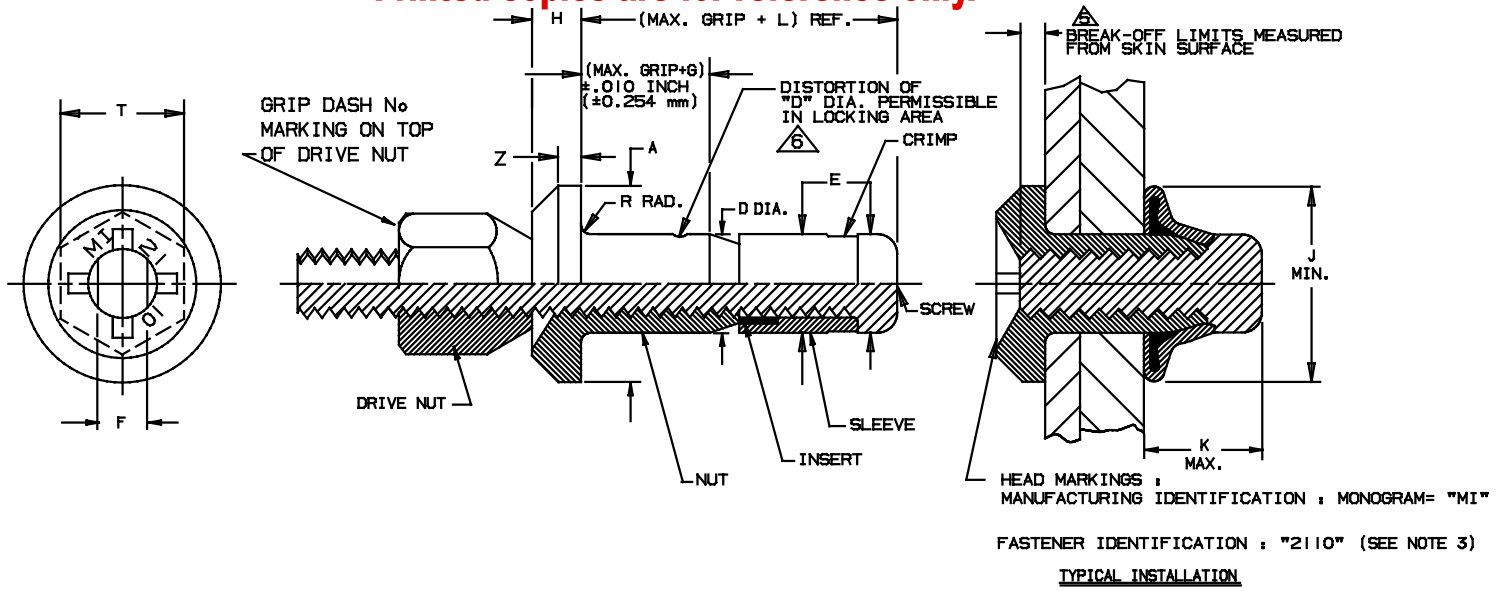

TABLE I

PART NUMBER	A DIA.		D DIA.		E DIA. MAX.		F WRENCH FLATS		G REF.		H		L REF.		R RAD. MAX.		T ACROSS HEX. REF.		Z MAX.		
	INCH	mm	INCH	mm	INCH	mm	INCH	mm	INCH	mm	INCH	mm	INCH	mm	INCH	mm	INCH	mm	INCH	mm	
MBF2110-5-()	.354 .334	8,99 8,48	.1645 .1625	4,178 4,128	.1640	4,166	.085 .080	2,16 2,03	.017 0,43	.060 .053	1,524 1,346	.512 13,00	.030 0,76	.375 9,52	.030 0,762						
MBF2110-6-()	.416 .396	10,57 10,06	.1985 .1965	5,042 4,991	.1985	5,042	.113 .108	2,87 2,74	.027 0,68	.070 .063	1,778 1,800	.575 14,61	.030 0,76	.375 9,52	.030 0,762						
MBF2110-7-()	.416 .396	10,57 10,06	.2275 .2255	5,778 5,728	.2275	5,778	.121 .116	3,07 2,95	.035 0,89	.070 .063	1,778 1,800	.635 16,13	.030 0,76	.375 9,52	.030 0,762						
MBF2110-8-()	.541 .521	13,74 13,23	.2595 .2575	6,591 6,541	.2595	6,591	.135 .130	3,43 3,30	.055 1,40	.085 .078	2,159 1,981	.700 17,78	.030 0,76	.375 9,52	.040 1,016						
MBF2110-9-()	.541 .521	13,74 13,23	.2895 .2875	7,353 7,303	.2895	7,353	.152 .147	3,86 3,73	.065 1,65	.085 .078	2,159 1,981	.815 20,70	.030 0,76	.500 12,70	.040 1,016						
MBF2110-10-()	.635 .615	16,13 15,62	.3115 .3095	7,912 7,861	.3110	7,899	.152 .147	3,86 3,73	.070 1,78	.105 .098	2,667 2,489	.892 22,66	.040 1,02	.500 12,70	.045 1,143						
MBF2110-11-()	.635 .615	16,13 15,62	.3435 .3415	8,725 8,674	.3433	8,720	.185 .180	4,70 4,57	.075 1,90	.105 .098	2,667 2,489	.941 23,90	.040 1,02	.500 12,70	.045 1,143						
MBF2110-12-()	.760 .740	19,30 18,80	.3745 .3725	9,512 9,462	.3740	9,500	.185 .180	4,70 4,57	.080 2,03	.125 .118	3,175 2,997	1,090 27,69	.040 1,02	.500 12,70	.045 1,143						

U.S. PATENT NO. 3643544, 4747202 & 4967463
 EUROPEAN PATENT NO. 0152531 & 0216980

MONOGRAM
 CODE IDENT. NO.
 98524

APPROVED DATE
 08-07-84 ECN# 3923
 REV. LETTER & DATE
 ECN # 3975
 "V" 12-05-06

NOTICE: THIS DRAWING IS PART OF THE PROPRIETARY ARTICLE HEREIN DISCLOSED. OWNED BY MONOGRAM AEROSPACE FASTENERS, ANY PARTY BY ACCEPTING THIS DOCUMENT ASSUMES CUSTODY THEREOF AND AGREES: A. THE INFORMATION SET FORTH HEREIN IS GIVEN IN CONFIDENCE AND THIS DOCUMENT WILL NOT BE COPIED OR REPRODUCED IN WHOLE OR IN PART, NOR ITS CONTENTS REVEALED IN ANY MANNER TO ANY PERSON EXCEPT TO MEET THE PURPOSE FOR WHICH IT WAS DELIVERED. B. WITHOUT THE WRITTEN CONSENT OF MONOGRAM AEROSPACE FASTENERS, THIS DOCUMENT AND THE INFORMATION CONTAINED HEREIN UNDER NO CIRCUMSTANCES WILL BE USED IN THE MANUFACTURE OR REPRODUCTION OF THE ARTICLE DISCLOSED, AND DELIVERY OF THIS DOCUMENT SHALL NOT CONSTITUTE ANY RIGHT OR LICENSE TO DO SO.

TITLE
 BLIND FASTENER LOW PROFILE PROTRUDING HEAD
 FOR ADVANCED COMPOSITE MATERIALS
 TITANIUM

STANDARD
 MBF 2110
 SHEET 1 OF 2

APPLICABLE SPECIFICATIONS: PROCUREMENT SPECIFICATION: MBF 2000.
INSTALLATION & INSPECTION SPECIFICATION MBF 2001.
SPECIAL LUBE AND FINISH: MBF 2002.
PART NUMBER ASSIGNMENT: MBF 2004.

TABLE I (CONT)

PART NUMBER	MINIMUM AVAILABLE GRIP LENGTH	INSTALLED DIMENSIONS								MECHANICAL PROPERTIES					
		RECOMMENDED HOLE SIZE		J DIA. MIN.		K MAX.		BREAK-OFF LIMITS Δ		TENSILE STRUCTURAL FAILURE (MIN.)		DOUBLE SHEAR MIN.		LOCKING TORQUE MIN.	
		INCH	mm	INCH	mm	INCH	mm	INCH	mm	LBS.	N	LBS.	N	IN-LBS	Nm
MBF2110-5-()	-100	.168 .165	4,27 4,19	.250	6,35	.300	7,62	+.103 -.000	+2,62 -0,00	900	4000	3150	14010	1.0	0,113
MBF2110-6-()	-100	.202 .199	5,13 5,05	.300	7,62	.350	8,89	+.103 -.000	+2,62 -0,00	1400	6230	4600	20460	1.5	0,170
MBF2110-7-()	-100	.231 .228	5,88 5,79	.350	8,89	.400	10,16	+.103 -.000	+2,62 -0,00	1600	7120	6050	26910	2.0	0,226
MBF2110-8-()	-150	.263 .260	6,68 6,60	.400	10,16	.450	11,43	+.103 -.000	+2,62 -0,00	2100	9340	7900	35140	2.5	0,282
MBF2110-9-()	-150	.293 .290	7,44 7,37	.450	11,43	.500	12,70	+.103 -.000	+2,62 -0,00	2600	11565	9800	43590	3.0	0,339
MBF2110-10-()	-150	.315 .312	8,00 7,92	.475	12,06	.550	13,97	+.103 -.000	+2,62 -0,00	3600	16010	11350	50480	3.5	0,400
MBF2110-11-()	-150	.347 .344	8,81 8,74	.525	13,33	.575	14,60	+.103 -.000	+2,62 -0,00	4400	19570	13850	61600	4.0	0,452
MBF2110-12-()	-150	.378 .375	9,60 9,52	.575	14,60	.625	15,87	+.103 -.000	+2,62 -0,00	5000	22240	16450	73170	4.0	0,452

MATERIAL AND HEAT TREAT:

NUT: 6Al-4V TITANIUM PER MIL-T-9047 STA OR AMS4928 OR AMS4967 HEAT TREATED PER MIL-H-81200 TO 95 KSI SHEAR STRENGTH MINIMUM. MAXIMUM HYDROGEN CONTENT 125 PPM.

SCREW: A-286 PER AMS 5731, AMS 5732 OR AMS 5737 HEAT TREATED TO 175 KSI TENSILE MINIMUM.

SLEEVE: 304 STAINLESS STEEL PER AMS 5639, FULLY ANNEALED.

INSERT: ACETAL PER ASTM D4181.

DRIVE NUT: MILD STEEL (COLOR GRAY).

TABLE II

FINISH: (-) NUT: KAL-GARD ANN-RO #1012 CONVERSION COATING OR PHOSPHATE FLOURIDE PER MONOGRAM SPECIFICATION P5741, MAY BE USED AT MANUFACTURER'S OPTION.

SLEEVE & SCREW: PASSIVATE PER ASTM A 967-96, KAL GARD ANN-RO #1013 CONVERSION COATING OPTIONAL.

INSERT: NONE.

DRIVE NUT: COLOR GRAY.

LUBRICANTS: DRY FILM LUBE PER MIL-L-46010 TYPE I OR EVERLUBE #812 PER MIL-L-81329, PARAFFIN WAX, OR CETYL ALCOHOL PER MIL-L-87132.

GENERAL NOTES:

1.) EXAMPLE OF PART NUMBER:

MBF 2110 (-) - 6 - 100 (-)

- L "A" DESIGNATES ROBOTIC APPLICATION; "DN" DESIGNATES ALUMINUM COATED DRIVE NUTS
- DESIGNATES GRIP (TABLE II)
- SEE NOTE Δ
- DESIGNATES BASIC DIMENSIONS (TABLE I)
- DESIGNATES SPECIAL FINISH CODE
- DESIGNATES BASIC PART NUMBER (BASIC PART: MBF2110SA(-)-6-100 USED FOR SEALANT APPLICATION ONLY.)

2.) LOCKING FEATURE CONSISTS OF THREE (3) INDENTATIONS LOCATED 120° APART ON THE PERIPHERY OF THE NUT COMPONENT AND APPROXIMATELY .040" ABOVE INTERSECTION OF THE NUT NOSE ANGLE AND O.D.

3.) ALTERNATE HEAD MARKING: "MI" AND "2010".

4.) COMPOSI-LOK FASTENERS WITH SELECTED COMBINATIONS OF THE ABOVE LUBRICANTS AND FINISHES ARE SPECIALLY CODED AND MAY BE SUBSTITUTED FOR EQUIVALENT NON-CODED PARTS AT MANUFACTURER'S OPTION. SEE INTERCHANGEABILITY SPECIFICATION MBF2007.

Δ AN "L" IN PLACE OF THE DASH (-) BETWEEN THE DIAMETER DASH NUMBER AND THE GRIP DASH NUMBER DESIGNATES MODIFIED BREAK-OFF LIMITS OF +.053/-0.050. "e.g. MBF 2110(-)-6L200".

Δ DISTORTION SHALL NOT PREVENT INSERTION OF THE FASTENER INTO A RING GAUGE OF LENGTH EQUAL TO ONE DIAMETER AND HOLE DIAMETER EQUAL TO A MINIMUM RECOMMENDED HOLE. FORCE FOR INSERTION SHALL NOT EXCEED 5.0 POUNDS.

2ND DASH NO. (GRIP)	GRIP RANGE			
	MIN. GRIP		MAX. GRIP	
	INCH	mm	INCH	mm
100	.050	1,27	.100	2,54
150	.100	2,54	.150	3,81
200	.150	3,81	.200	5,08
250	.200	5,08	.250	6,35
300	.250	6,35	.300	7,62
350	.300	7,62	.350	8,89
400	.350	8,89	.400	10,16
450	.400	10,16	.450	11,43
500	.450	11,43	.500	12,70
550	.500	12,70	.550	13,97
600	.550	13,97	.600	15,24
650	.600	15,24	.650	16,51
700	.650	16,51	.700	17,78
750	.700	17,78	.750	19,05
800	.750	19,05	.800	20,32
850	.800	20,32	.850	21,59
900	.850	21,59	.900	22,86
950	.900	22,86	.950	24,13
1000	.950	24,13	1.000	25,40
1050	1.000	25,40	1.050	26,67
1100	1.050	26,67	1.100	27,94
1150	1.100	27,94	1.150	29,21
1200	1.150	29,21	1.200	30,48
1250	1.200	30,48	1.250	31,75
1300	1.250	31,75	1.300	33,02
1350	1.300	33,02	1.350	34,29
1400	1.350	34,29	1.400	35,56
1450	1.400	35,56	1.450	36,83
1500	1.450	36,83	1.500	38,10
1550	1.500	38,10	1.550	39,37
1600	1.550	39,37	1.600	40,64
1650	1.600	40,64	1.650	41,91
1700	1.650	41,91	1.700	43,18

U.S. PATENT NO. 3643544, 4747202 & 4967463
EUROPEAN PATENT NO. 0152531 & 0216980

MONOGRAM

CODE IDENT. NO.
98524

APPROVED DATE
08-07-84 ECN# 3923

REV. LETTER & DATE
ECN # 3975
"V" 12-05-06

NOTICE: THIS DRAWING IS PART OF THE PROPRIETARY ARTICLE HEREIN DISCLOSED, OWNED BY MONOGRAM AEROSPACE FASTENERS. ANY PARTY BY ACCEPTING THIS DOCUMENT ASSUMES CUSTODY THEREOF AND AGREES: A. THE INFORMATION SET FORTH HEREIN IS GIVEN IN CONFIDENCE AND THIS DOCUMENT WILL NOT BE COPIED OR REPRODUCED IN WHOLE OR IN PART NOR ITS CONTENTS REVEALED IN ANY MANNER TO ANY PERSON EXCEPT TO MEET THE PURPOSE FOR WHICH IT WAS DELIVERED. B. WITHOUT THE WRITTEN CONSENT OF MONOGRAM AEROSPACE FASTENERS, THIS DOCUMENT AND THE INFORMATION CONTAINED HEREIN UNDER NO CIRCUMSTANCES WILL BE USED IN THE MANUFACTURE OR REPRODUCTION OF THE ARTICLE DISCLOSED AND DELIVERY OF THIS DOCUMENT SHALL NOT CONSTITUTE ANY RIGHT OR LICENSE TO DO SO.

TITLE
BLIND FASTENER LOW PROFILE PROTRUDING HEAD
FOR ADVANCED COMPOSITE MATERIALS
TITANIUM

STANDARD
MBF 2110
SHEET 2 OF 2