

Printed copies are for reference only.

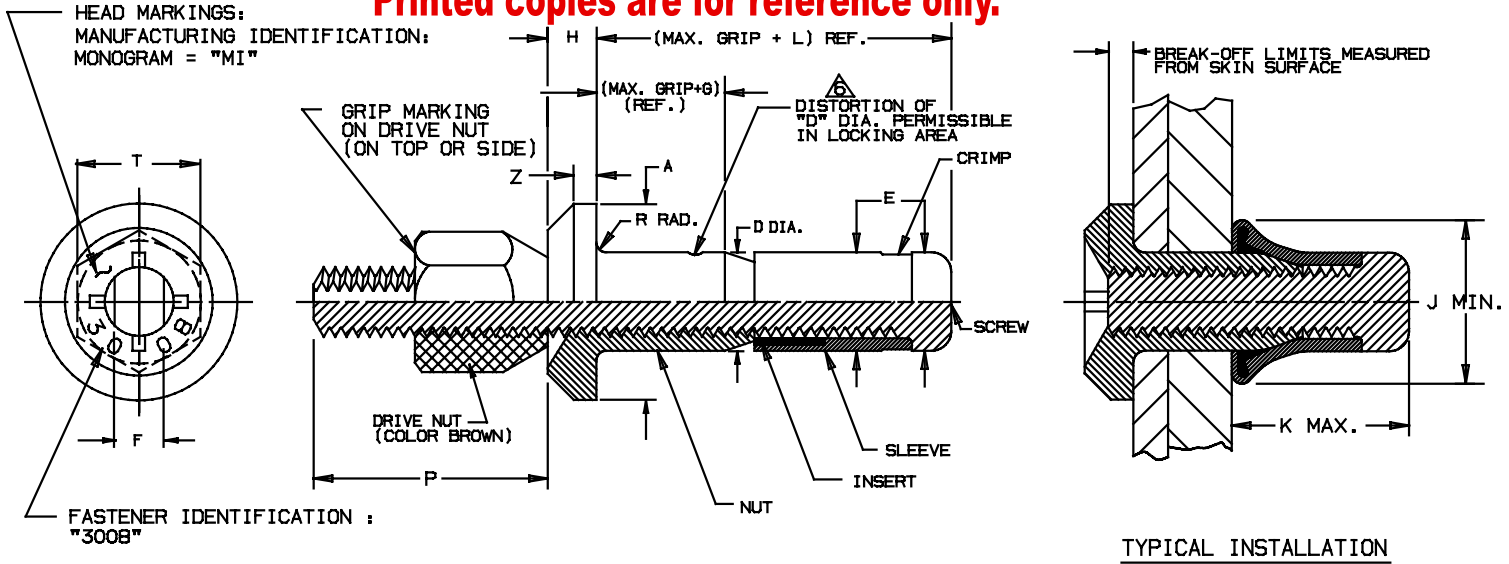

PART NUMBER	A DIA.		D DIA.		E DIA. MAX.		F WRENCH FLATS		G REF.		H		L REF.		R RAD. MAX.		T ACROSS HEX. REF.		Z MAX.	
	INCH	mm	INCH	mm	INCH	mm	INCH	mm	INCH	mm	INCH	mm	INCH	mm	INCH	mm	INCH	mm	INCH	mm
MBF300B-5-()	.354 .334	8,99 8,48	.1645 .1625	4,178 4,126	.1640	4,166	.085 .080	2,16 2,03	.058	1,47	.060 .053	1,524 1,346	.625	15,875	.030	0,76	.375	9,52	.030	0,762
MBF300B-6-()	.416 .396	10,57 10,06	.1985 .1965	5,042 4,991	.1985	5,042	.113 .108	2,87 2,74	.058	1,47	.070 .063	1,778 1,600	.675	17,145	.030	0,76	.375	9,52	.030	0,762
MBF300B-7-()	.416 .396	10,57 10,06	.2275 .2255	5,778 5,728	.2275	5,778	.121 .116	3,07 2,95	.058	1,47	.070 .063	1,778 1,600	.862	21,894	.030	0,76	.375	9,52	.030	0,762
MBF300B-8-()	.541 .521	13,74 13,23	.2595 .2575	6,591 6,541	.2595	6,591	.135 .130	3,43 3,30	.058	1,47	.085 .078	2,159 1,981	.900	22,860	.030	0,76	.375	9,52	.040	1,016
MBF300B-9-()	.541 .521	13,74 13,23	.2895 .2875	7,353 7,303	.2895	7,353	.152 .147	3,86 3,73	.068	1,73	.085 .078	2,159 1,981	.930	23,622	.030	0,76	.500	12,70	.040	1,016
MBF300B-10-()	.635 .615	16,13 15,62	.3115 .3095	7,912 7,861	.3110	7,899	.152 .147	3,86 3,73	.073	1,85	.105 .098	2,667 2,489	.912	23,164	.040	1,02	.500	12,70	.045	1,143
MBF300B-11-()	.635 .615	16,13 15,62	.3435 .3415	8,725 8,674	.3433	8,720	.185 .180	4,70 4,57	.078	1,98	.105 .098	2,667 2,489	1.000	25,400	.040	1,02	.500	12,70	.045	1,143
MBF300B-12-()	.760 .740	19,30 18,80	.3745 .3725	9,512 9,462	.3740	9,500	.185 .180	4,70 4,57	.083	2,11	.125 .118	3,175 2,997	1.100	27,940	.040	1,02	.500	12,70	.045	1,143

TABLE I (CONT)

PART NUMBER	MINIMUM AVAILABLE GRIP GRIP NO.	INSTALLED DIMENSIONS						MECHANICAL PROPERTIES									
		RECOMMENDED HOLE SIZE		J DIA. MIN.		K MAX.		BREAK-OFF LIMITS		TENSILE STRUCTURAL FAILURE (MIN.)		DOUBLE SHEAR MIN.		LOCKING TORQUE MIN.		P MAX.	
		INCH	mm	INCH	mm	INCH	mm	INCH	mm	LBS.	N	LBS.	N	IN-LBS	Nm	INCH	mm
MBF300B-5-()	-100	.168 .165	4,27 4,19	.250	6,35	.370	9,40	+.103 -.000	+2,62 -.000	900	4000	3150	14010	1.0	0,113	.800	20,32
MBF300B-6-()	-100	.202 .199	5,13 5,05	.300	7,62	.420	10,67			1400	6230	4600	20460	1.5	0,170	.850	21,59
MBF300B-7-()	-100	.231 .228	5,88 5,79	.350	8,89	.490	12,45			1600	7120	6050	26910	2.0	0,226	1.000	25,40
MBF300B-8-()	-150	.263 .260	6,68 6,60	.400	10,16	.510	12,95			2100	9340	7900	35140	2.5	0,282	1.100	27,94
MBF300B-9-()	-150	.293 .290	7,44 7,37	.450	11,43	.535	13,59			2600	11565	9800	43590	3.0	0,339	1.250	31,75
MBF300B-10-()	-150	.315 .312	8,00 7,92	.475	12,06	.540	13,72			3600	16010	11350	50480	3.5	0,400	1.050	26,67
MBF300B-11-()	-150	.347 .344	8,81 8,74	.525	13,33	.670	17,02			4400	19570	13850	61600	4.0	0,452	1.150	29,21
MBF300B-12-()	-150	.378 .375	9,60 9,52	.565	14,35	.675	17,15			5000	22240	16450	73170	4.0	0,452	1.250	31,75

U.S. PATENT NO. 4747202, 4772167 AND 4967463
 EUROPEAN PATENT NO. 0152531 & 0244783

MONOGRAM
 CODE IDENT. NO.
 98524

APPROVED DATE
 ECN #5218
 01-05-86

REV. LETTER & DATE
 ECN # 1167
 "K" 11-14-01

NOTICE: THIS DRAWING IS PART OF THE PROPRIETARY ARTICLE HEREIN DISCLOSED. OWNED BY MONOGRAM AEROSPACE FASTENERS, ANY PARTY BY ACCEPTING THIS DOCUMENT ASSUMES CUSTODY THEREOF AND AGREES: A. THE INFORMATION SET FORTH HEREIN IS GIVEN IN CONFIDENCE AND THIS DOCUMENT WILL NOT BE COPIED OR REPRODUCED IN WHOLE OR IN PART, NOR ITS CONTENTS REVEALED IN ANY MANNER TO ANY PERSON EXCEPT TO MEET THE PURPOSE FOR WHICH IT WAS DELIVERED. B. WITHOUT THE WRITTEN CONSENT OF MONOGRAM AEROSPACE FASTENERS, THIS DOCUMENT AND THE INFORMATION CONTAINED HEREIN UNDER NO CIRCUMSTANCES WILL BE USED IN THE MANUFACTURE OR REPRODUCTION OF THE ARTICLE DISCLOSED, AND DELIVERY OF THIS DOCUMENT SHALL NOT CONSTITUTE ANY RIGHT OR LICENSE TO DO SO.

TITLE
 BLIND FASTENER LOW PROFILE PROTRUDING HEAD
 FOR ADVANCED COMPOSITE MATERIAL
 CRES

STANDARD
 MBF 300B
 SHEET 1 OF 2

PROCUREMENT SPECIFICATION: MBF 2008.
 INSTALLATION & INSPECTION SPECIFICATION : MBF 2009.
 SPECIAL LUBRICANT & FINISH CODES : MBF 2002.
 MATERIAL AND HEAT TREAT: NUT: A-286 STAINLESS STEEL PER CHEMICAL REQUIREMENTS OF AMS 5732. HEAT TREATED AS REQUIRED FOR PERFORMANCE.
 SCREW: A-286 PER AMS 5731, AMS 5732 OR AMS 5737 HEAT TREATED TO 175 KSI TENSILE MINIMUM.
 SLEEVE: 304 STAINLESS STEEL PER AMS 5639 FULLY ANNEALED.
 INSERT: ACETAL PER ASTM D4181.
 DRIVE NUT: MILD STEEL.
 FINISH: NUT, SLEEVE & SCREW : PASSIVATE PER QQ-P-35 KAL GARD CONVERSION COATING ANN-RO #1013 OPTIONAL.
 INSERT: NONE.
 DRIVE NUT : COLOR BROWN.
 LUBRICANT: DRY FILM LUBRICANT PER MIL-L-46010 TYPE I, CETYL ALCOHOL PER MIL-L-87132, AND/OR PARAFFIN WAX. (OPTIONAL AS REQUIRED FOR PERFORMANCE).

GENERAL NOTES: 1.) EXAMPLE OF PART NUMBER:

TABLE II

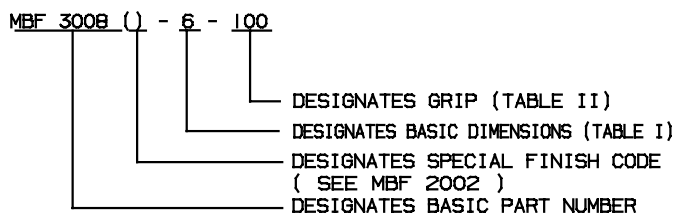

2ND DASH NO. (GRIP)	GRIP RANGE			
	MIN. GRIP		MAX. GRIP	
	INCH	mm	INCH	mm
100	.050	1,27	.100	2,54
150	.100	2,54	.150	3,81
200	.150	3,81	.200	5,08
250	.200	5,08	.250	6,35
300	.250	6,35	.300	7,62
350	.300	7,62	.350	8,89
400	.350	8,89	.400	10,16
450	.400	10,16	.450	11,43
500	.450	11,43	.500	12,70
550	.500	12,70	.550	13,97
600	.550	13,97	.600	15,24
650	.600	15,24	.650	16,51
700	.650	16,51	.700	17,78
750	.700	17,78	.750	19,05
800	.750	19,05	.800	20,32
850	.800	20,32	.850	21,59
900	.850	21,59	.900	22,86
950	.900	22,86	.950	24,13
1000	.950	24,13	1.000	25,40
1050	1.000	25,40	1.050	26,67
1100	1.050	26,67	1.100	27,94
1150	1.100	27,94	1.150	29,21

- 2.) LOCKING FEATURE CONSISTS OF THREE (3) INDENTATIONS LOCATED 120° APART ON THE PERIPHERY OF THE NUT COMPONENT AND APPROXIMATELY .040 ABOVE THE INTERSECTION OF THE NUT NOSE ANGLE AND O.D.
- 3.) SEE MBF 2009 FOR INSTALLATION AND REMOVAL INFORMATION.
- 4.) COMPOSI-LOK FASTENERS WITH SELECTED COMBINATIONS OF THE ABOVE LUBRICANTS AND FINISHES ARE SPECIALLY CODED AND MAY BE SUBSTITUTED FOR EQUIVALENT NON-CODED PARTS AT MANUFACTURER'S OPTION. SEE INTERCHANGEABILITY SPECIFICATION MBF 2007.
- 5.) THESE PARTS ARE SIMILAR TO MBF 2120 EXCEPT AS FOLLOWS :
- A.) IMPROVED OUT-OF-GRIP FLAGGING CAPABILITY (SCREW B/O).
 - B.) INCREASED BLIND SIDE PROTRUSION BEFORE AND AFTER UPSET.
 - C.) INCREASED INSTALLED WEIGHT.
- 6.) DISTORTION SHALL NOT PREVENT INSERTION OF THE FASTENER INTO A RING GAUGE OF LENGTH EQUAL TO ONE DIAMETER AND DIAMETER EQUAL TO MINIMUM RECOMMENDED HOLE SIZE. FORCE FOR INSERTION SHALL NOT EXCEED 5.0 POUNDS.

U.S. PATENT NO. 4747202, 4772167 AND 4967463
 EUROPEAN PATENT NO. 0152531 & 0244783

MONOGRAM

CODE IDENT. NO.
 98524

APPROVED DATE ECN #5218 01-05-86	NOTICE: THIS DRAWING IS PART OF THE PROPRIETARY ARTICLE HEREIN DISCLOSED. OWNED BY MONOGRAM AEROSPACE FASTENERS, ANY PARTY BY ACCEPTING THIS DOCUMENT ASSUMES CUSTODY THEREOF AND AGREES: A. THE INFORMATION SET FORTH HEREIN IS GIVEN IN CONFIDENCE AND THIS DOCUMENT WILL NOT BE COPIED OR REPRODUCED IN WHOLE OR IN PART, NOR ITS CONTENTS REVEALED IN ANY MANNER TO ANY PERSON EXCEPT TO MEET THE PURPOSE FOR WHICH IT WAS DELIVERED. B. WITHOUT THE WRITTEN CONSENT OF MONOGRAM AEROSPACE FASTENERS, THIS DOCUMENT AND THE INFORMATION CONTAINED HEREIN UNDER NO CIRCUMSTANCES WILL BE USED IN THE MANUFACTURE OR REPRODUCTION OF THE ARTICLE DISCLOSED, AND DELIVERY OF THIS DOCUMENT SHALL NOT CONSTITUTE ANY RIGHT OR LICENSE TO DO SO.	TITLE BLIND FASTENER LOW PROFILE PROTRUDING HEAD FOR ADVANCED COMPOSITE MATERIAL CRES	STANDARD MBF 3008 SHEET 2 OF 2
REV. LETTER & DATE ECN # 1167 "K" 11-14-01			