

Printed copies are for reference only.

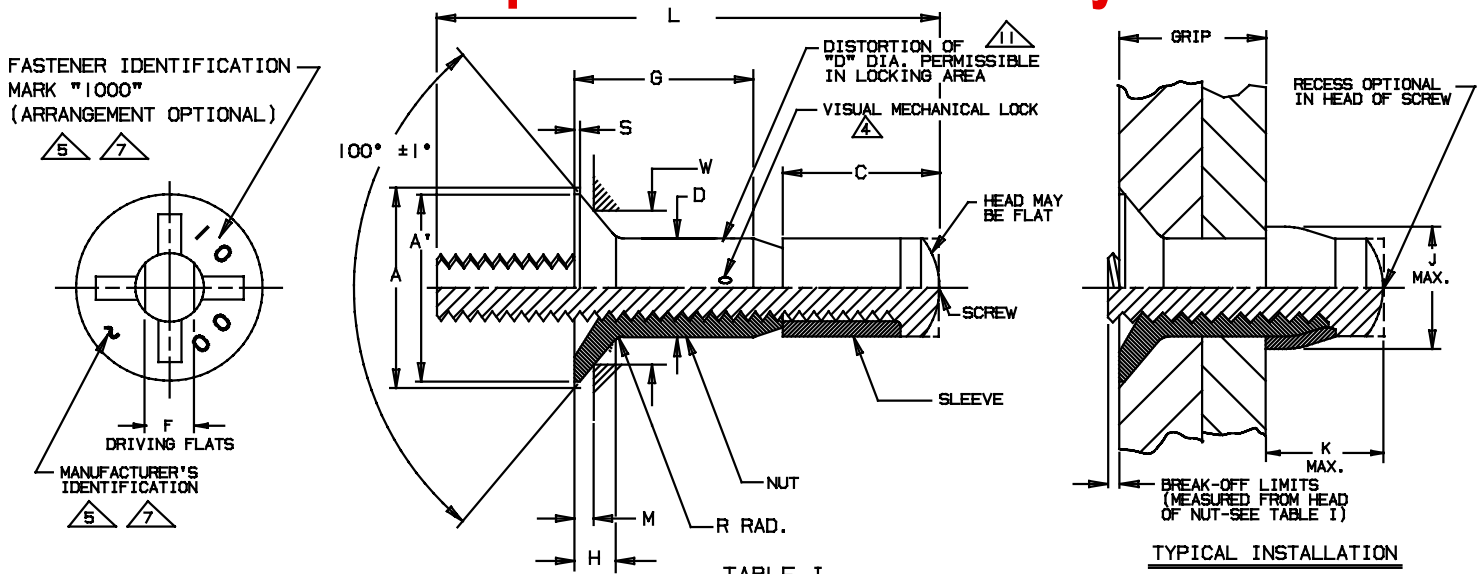

TABLE I

PART NUMBER	NOM. DIA.	A THEO. DIA.	A' DIA. MIN.	C MAX.	D DIA.	F DRIVING FLATS	H REF.	J DIA. MAX.	K MAX.	M GAGE PROT.	R RAD.	S MAX.	W GAGE DIA.	HOLE SIZE	BREAK-OFF LIMITS	PREVAILING TORQUE IN-LBS MIN	DOUBLE SHEAR STRENGTH LBS. MIN.	TENSILE STRENGTH LBS. MIN.
PLT1000-5-(*)	.1635	.332 .325	.296	.268	.1645 .1625	.086 .081	.069	.244	.267	.0276 .0238	.030 .010	.012	.2671 .2667	.168 .165	+0.020 -.068	1.0	3760	970
PLT1000-6-(*)	.1980	.385 .378	.342	.303	.1990 .1970	.104 .099	.077	.300	.302	.0299 .0259	.030 .015	.015	.3147 .3143	.202 .199	+0.015 -.073	1.5	5240	1400
PLT1000-8-(*)	.2590	.507 .499	.463	.354	.2600 .2580	.135 .130	.102	.384	.346	.0353 .0307	.030 .015	.015	.4245 .4241	.263 .260	+0.010 -.078	2.5	9300	2100
PLT1000-10-(*)	.3105	.635 .626	.577	.423	.3115 .3095	.152 .147	.134	.427	.414	.0409 .0357	.040 .020	.020	.5389 .5385	.315 .312	+0.010 -.083	3.5	14600	3600
PLT1000-12-(*)	.3735	.762 .752	.696	.510	.3745 .3725	.185 .180	.160	.516	.470	.0466 .0407	.040 .020	.023	.6532 .6528	.378 .375	+0.010 -.093	4.0	21000	5650

(\*) SEE TABLE II FOR SECOND DASH NUMBER AND APPROVED CALLOUT.

TABLE II

SECOND DASH NUMBER	G GRIP	GRIP RANGE		L REF.					SECOND DASH NUMBER	G GRIP	GRIP RANGE		L REF.				
		MIN.	MAX.	PLT 1000							MIN.	MAX.	PLT 1000				
				-5-(*)	-6-(*)	-8-(*)	-10-(*)	-12-(*)					-5-(*)	-6-(*)	-8-(*)	-10-(*)	-12-(*)
-	-	-	-	-	-	-	-	-	-17	1.094	1.032	1.094	NOT AVAILABLE	1.791	1.819	1.971	2.054
-2	.156	.094	.156	.733	.853	-	-	-18	1.156	1.095	1.156	1.853		1.881	2.033	2.117	
-3	.219	.157	.219	.795	.916	.944	-	-19	1.219	1.157	1.219	1.916		1.944	2.096	2.179	
-4	.281	.220	.281	.858	.978	1.006	1.158	1.242	-20	1.281	1.220	1.281		1.978	2.006	2.158	2.242
-5	.344	.282	.344	.920	1.041	1.069	1.221	1.304	-21	1.344	1.282	1.344		2.041	2.069	2.221	2.304
-6	.406	.345	.406	.983	1.103	1.131	1.283	1.367	-22	1.406	1.345	1.406	2.103	2.131	2.283	2.367	
-7	.469	.407	.469	1.045	1.166	1.194	1.346	1.429	-23	1.469	1.407	1.469	IN DIAMETER	2.166	2.194	2.346	2.429
-8	.531	.470	.531	1.108	1.228	1.256	1.408	1.492	-24	1.531	1.470	1.531		2.228	2.256	2.408	2.492
-9	.594	.532	.594	1.170	1.291	1.319	1.471	1.554	-25	1.594	1.532	1.594	-5 DIAMETER	2.291	2.319	2.471	2.554
-10	.656	.595	.656	1.233	1.353	1.381	1.533	1.617	-26	1.656	1.595	1.656		2.353	2.381	2.533	2.617
-11	.719	.657	.719	1.295	1.416	1.444	1.596	1.679	-27	1.719	1.657	1.719	2.416	2.444	2.596	2.679	
-12	.781	.720	.781	1.358	1.478	1.506	1.658	1.742	-28	1.781	1.720	1.781	2.478	2.506	2.658	2.742	
-13	.844	.782	.844	1.420	1.541	1.569	1.721	1.804	-29	1.844	1.782	1.844	2.541	2.569	2.721	2.804	
-14	.906	.845	.906	1.483	1.603	1.631	1.783	1.867	-30	1.906	1.845	1.906	2.603	2.631	2.783	2.867	
-15	.969	.907	.969	1.545	1.666	1.694	1.846	1.929	-31	1.969	1.907	1.969	2.666	2.694	2.846	2.929	
-16	1.031	.970	1.031	1.608	1.728	1.756	1.908	1.992	-32	2.031	1.970	2.031	2.728	2.756	2.908	2.992	

\*G TOLERANCES: FOR -5 & -6 SIZES +.030/-0.010; FOR -8 & -10 SIZES +.040/-0.010; FOR -12 SIZE +.050/-0.010.

U.S. PATENT NO. 3643544, OTHER PATENTS PENDING.

**Fairchild**  
 CODE IDENT. NO.  
**92215**

**MONOGRAM**  
 CODE IDENT. NO.  
**98524**

APPROVED DATE  
 25 SEPTEMBER 1972

NOTICE: THIS DRAWING IS PART OF THE PROPRIETARY ARTICLE HEREIN DISCLOSED, OWNED BY MONOGRAM AEROSPACE FASTENERS, ANY PARTY BY ACCEPTING THIS DOCUMENT ASSUMES CUSTODY THEREOF AND AGREES: A. THE INFORMATION SET FORTH HEREIN IS GIVEN IN CONFIDENCE AND THIS DOCUMENT WILL NOT BE COPIED OR REPRODUCED IN WHOLE OR IN PART, NOR ITS CONTENTS REVEALED IN ANY MANNER TO ANY PERSON EXCEPT TO MEET THE PURPOSE FOR WHICH IT WAS DELIVERED. B. WITHOUT THE WRITTEN CONSENT OF MONOGRAM AEROSPACE FASTENERS, THIS DOCUMENT AND THE INFORMATION CONTAINED HEREIN UNDER NO CIRCUMSTANCES WILL BE USED IN THE MANUFACTURE OR REPRODUCTION OF THE ARTICLE DISCLOSED, AND DELIVERY OF THIS DOCUMENT SHALL NOT CONSTITUTE ANY RIGHT OR LICENSE TO DO SO.

TITLE  
**VISU-LOK, FASTENER, BLIND INTERNALLY THREADED, EXTERNAL SLEEVE ALLOY STEEL 100° FLUSH HEAD, SELF LOCKING HIGH STRENGTH**

**STANDARD**  
**PLT 1000**  
**SHEET 1 OF 2**

REV. LETTER AND DATE  
 ④ 04-11-94

PROCUREMENT SPEC. : ESCBB-2, CLASS I EXCEPT AS SPECIFIED HEREIN.

MATERIAL : NUT & SCREW : ALLOY STEEL; 4130 PER MIL-S-6758, 4140 PER MIL-S-5626 OR 8740 PER MIL-S-6049.

SLEEVE : CORROSION RESISTANT STEEL: 303 OR 304 PER QQ-S-763, AMS 5639 OR AMS 5641.

HEAT TREAT : NUT & SCREW : HEAT TREAT PER MIL-H-6875 TO Rc 39-46, AND TO VICKERS DPH390-465.

SLEEVE : AS REQUIRED FOR PERFORMANCE.

△ FINISH : NUT & SCREW : CADMIUM PLATE PER QQ-P-416, TYPE II, CLASS 2. CADMIUM PLATE PER NAS 672 IS PERMISSIBLE PROVIDED IT IS FOLLOWED BY A DICHROMATE POST TREATMENT PER QQ-P-416.

SLEEVE : PASSIVATE PER MIL-S-5002. CADMIUM PLATE PER QQ-P-416, TYPE I, CLASS 3.

△ LUBRICANT: LUBRICANTS LISTED BELOW MAY BE APPLIED TO ANY OR ALL COMPONENTS IF REQUIRED FOR FASTENER PERFORMANCE:

NUT : W/M CARBO-WAX, PARAFFIN WAX AND/OR CETYL ALCOHOL PER MIL-L-87132.

SCREW & SLEEVE : DRY FILM LUBE MoS<sub>2</sub>, PER MIL-L-46010 OR MIL-L-81329, W/M CARBO-WAX, PARAFFIN WAX AND/OR CETYL ALCOHOL PER MIL-L-87132.

PART CODE & EXAMPLE :

PLT 1000 - 8 - 8

GRIP LENGTHS IN 1/16THS (SEE TABLE II).

NOMINAL BODY DIAMETER AS TABULATED.

BASIC PART NUMBER, SELF LOCKING BLIND FASTENER.

GENERAL NOTES :

- 1.) OUTSIDE DIAMETER OF HEAD OF SCREW AND OUTSIDE DIAMETER OF SLEEVE SHALL NOT BE GREATER THAN MAXIMUM "D" DIAMETER.
- 2.) CONCENTRICITY OF NUT HEAD CONICAL SURFACE TO "D" DIAMETER SHALL BE WITHIN .005 T.I.R. (EXCEPT OVER INDENTS).
- 3.) REMOVE ALL LOOSE OR HANGING BURRS.
- △ 4.) LOCKING FEATURE CONSISTS OF THREE (3) INDENTATIONS LOCATED 120° APART ON THE PERIPHERY OF THE NUT COMPONENT AND APPROXIMATELY .040 ABOVE THE INTERSECTION OF THE NUT NOSE ANGLE AND O.D. (MEAN GRIP OF FASTENER).
- △ 5.) MANUFACTURER'S IDENTIFICATION: LETTER "N" DESIGNATES MONOGRAM/AEROSPACE FASTENERS. LETTERS "VS" DESIGNATE VOI-SHAN.
- 6.) HEAD MARKINGS ON NUT DEPRESSED .010 MAX.
- △ 7.) THE PRODUCT DESCRIBED BY THIS DRAWING IS "EQUIVALENT TO" AND "INTERCHANGEABLE WITH" THE MANUFACTURER'S PRODUCT LISTED BELOW EXCEPT FOR THE HEAD IDENTIFICATION MARKINGS AND SELF-LOCKING FEATURE. EXISTING STOCK MAY BE REWORKED TO INCORPORATE THE LOCK. WHEN THESE REWORKED FASTENERS ARE SUPPLIED, THE HEAD IDENTIFICATION MAY BE AS SHOWN BELOW :  
 MONOGRAM... : WF164-WF375 SERIES (MARKING: "N" AND OVERSTAMPED "L" OR "SL").  
 VOI-SHAN... : BAAF SERIES (MARKING: "VS", "A", AND "SL").
- △ 8.) STANDARD FINISHES AND LUBRICANTS ARE SHOWN ABOVE. REFER TO SPECIFICATION ESCBB-4 FOR SPECIAL FINISHES AND/OR LUBRICANTS, IF REQUIRED.
- △ 9.) HALF-GRIP SIZES MAY BE ORDERED BY ADDING (.5) TO THE GRIP DASH NUMBERS.  
 EXAMPLE: PLT 1000-6-4.5 INDICATES A NOMINAL GRIP LENGTH OF 4.5 SIXTEENTHS = .281. THE GRIP RANGE FOR THESE HALF-GRIP SIZES WILL BE NOMINAL GRIP + .031/- .030. THE BASIC "G" DIMENSION WILL BE NOMINAL GRIP + .031 AND THE OVERALL SCREW LENGTH "L" DIMENSION MAY VARY AT MANUFACTURER'S OPTION.
- △ 10.) STANDARD GRIP LENGTHS ARE SHOWN IN TABLE II, SHORTER OR LONGER GRIPS THAN THOSE LISTED MAY BE AVAILABLE AS SPECIALS. ON GRIP LENGTHS SHORTER THAN THOSE LISTED, THE BREAKOFF LIMITS AND PREVAILING TORQUES SHOWN IN TABLE I DO NOT APPLY.
- △ 11.) DISTORTION OF "D" DIAMETER SHALL NOT PREVENT INSERTION OF THE FASTENER INTO A RING GAUGE OF LENGTH EQUAL TO ONE DIAMETER AND DIAMETER EQUAL TO MAXIMUM "D" + .001" FORCE FOR INSERTION SHALL NOT EXCEED FIVE (5) POUNDS.
- △ 12.) THE PREVAILING TORQUE SHALL CONFORM TO THE VALUES AS TABULATED, WHEN TESTED IN ACCORDANCE WITH SPECIFICATION ESCBB-2. HOWEVER, PREVAILING TORQUES FOR THE PLT1000-5-1 AND PLT1000-6-1 SHALL BE RECORDED THRU A ROTATION OF ONLY 360° OF THE NUT.
- △ 13.) DIMENSIONS "A", "A'" AND "H" ARE FOR ENGINEERING REFERENCE PURPOSES ONLY AND ARE NOT TO BE USED FOR INSPECTION PURPOSES. THESE DIMENSIONS ARE THEORETICAL VALUES DERIVED FROM "D", "S", "V", "W" AND HEAD ANGLE DIMENSIONS.
14. DIMENSIONS ARE EXCLUSIVE OF LUBRICATION.

U.S. PATENT NO. 3643544, OTHER PATENTS PENDING.

Fairchild  
 CODE IDENT. NO.  
 92215

MONOGRAM  
 CODE IDENT. NO.  
 98524

APPROVED DATE  
 25 SEPTEMBER 1972

NOTICE: THIS DRAWING IS PART OF THE PROPRIETARY ARTICLE HEREIN DISCLOSED, OWNED BY MONOGRAM AEROSPACE FASTENERS. ANY PARTY BY ACCEPTING THIS DOCUMENT ASSUMES CUSTODY THEREOF AND AGREES:  
 A. THE INFORMATION SET FORTH HEREIN IS GIVEN IN CONFIDENCE AND THIS DOCUMENT WILL NOT BE COPIED OR REPRODUCED IN WHOLE OR IN PART, NOR ITS CONTENTS REVEALED IN ANY MANNER TO ANY PERSON EXCEPT TO MEET THE PURPOSE FOR WHICH IT WAS DELIVERED.  
 B. WITHOUT THE WRITTEN CONSENT OF MONOGRAM AEROSPACE FASTENERS, THIS DOCUMENT AND THE INFORMATION CONTAINED HEREIN UNDER NO CIRCUMSTANCES WILL BE USED IN THE MANUFACTURE OR REPRODUCTION OF THE ARTICLE DISCLOSED, AND DELIVERY OF THIS DOCUMENT SHALL NOT CONSTITUTE ANY RIGHT OR LICENSE TO DO SO.

TITLE  
 VISU-LOK, FASTENER, BLIND INTERNALLY THREADED, EXTERNAL SLEEVE ALLOY STEEL  
 100° FLUSH HEAD, SELF LOCKING HIGH STRENGTH

STANDARD  
 PLT 1000  
 SHEET 2 OF 2

REV. LETTER AND DATE  
 (E) 04-11-94