

Printed copies are for reference only.

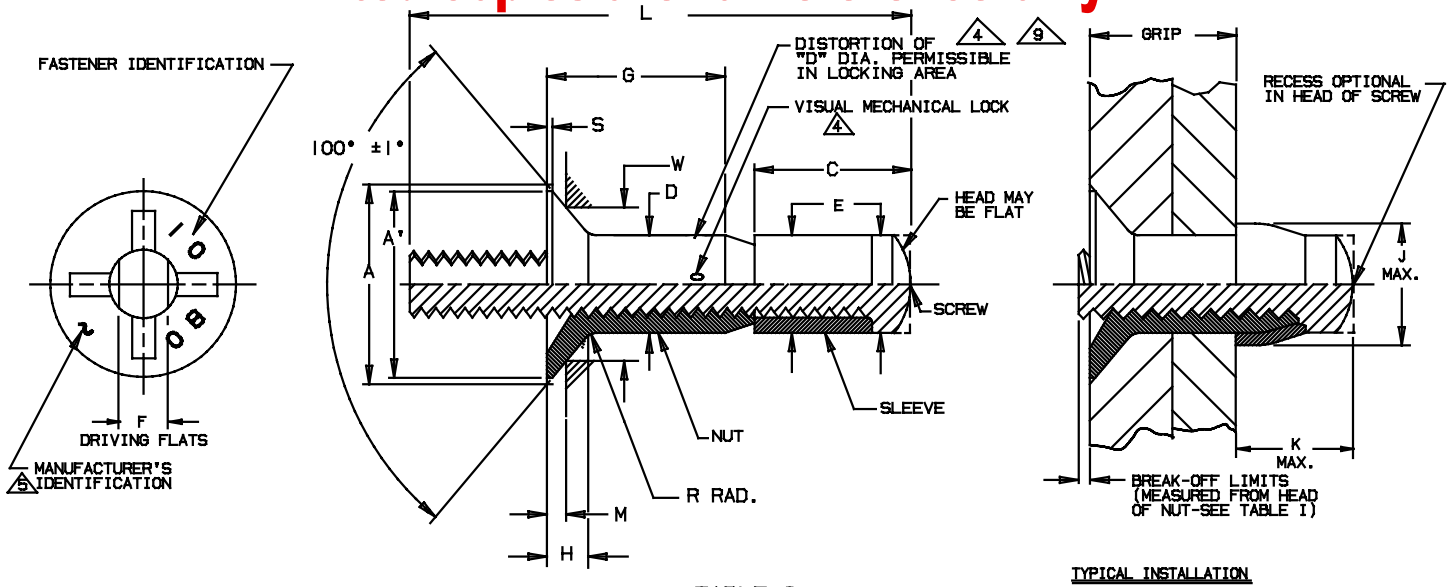

PART NUMBER	A THEO. DIA.	A' DIA. MIN.	C MAX.	D DIA.		E DIA. MAX.	F DRIVING FLATS	H REF.	J DIA. MAX.	K MAX.	M GAGE PROT.	R RAD.	S MAX.	W GAGE DIA.	HOLE SIZE	BREAK-OFF LIMITS	PREVAILING TORQUE IN. LBS. MIN.	DOUBLE SHEAR STRENGTH LBS. MIN.	TENSILE STRENGTH LBS. MIN.
				WITHOUT COATING OR SOLID FILM LUBE	WITH COATING OR SOLID FILM LUBE														
PLT 1080-5-(*)	.2612 .2564	.241	.285	.1680 .1675	.1680 .1670	.1645	.086 .081	.038	.244	.257	.0265 .0237	.030 .010	.010	.1992 .1990	.1720 .1690	+ .088 - .000	1.0	3150	750
PLT 1080-6-(*)	.3016 .2966	.270	.320	.2025 .2020	.2025 .2015	.1990	.104 .099	.041	.300	.288	.0246 .0218	.030 .015	.015	.2440 .2438	.2065 .2035	+ .088 - .000	1.5	4600	1250
PLT 1080-8-(*)	.3948 .3898	.363	.355	.2635 .2630	.2635 .2625	.2600	.135 .130	.054	.384	.320	.0271 .0242	.030 .015	.015	.3314 .3312	.2675 .2645	+ .088 - .000	2.5	7900	1900
PLT 1080-10-(*)	.4739 .4689	.442	.440	.3150 .3145	.3150 .3140	.3115	.152 .147	.066	.427	.396	.0296 .0268	.040 .020	.015	.4047 .4045	.3190 .3160	+ .103 - .000	3.5	11350	3250
PLT 1080-12-(*)	.5604 .5554	.529	.525	.3780 .3775	.3780 .3770	.3745	.185 .180	.076	.516	.473	.0321 .0290	.040 .020	.015	.4854 .4852	.3820 .3790	+ .103 - .000	4.0	16450	5050

(*) SEE TABLE II FOR SECOND DASH NUMBER AND APPROVED CALLOUT.

TABLE II

SECOND DASH NUMBER	Ø GRIP	GRIP RANGE		L REF.				
		MIN.	MAX.	PLT 1080-5-(*)	PLT 1080-6-(*)	PLT 1080-8-(*)	PLT 1080-10-(*)	PLT 1080-12-(*)
-	-	-	-	-	-	-	-	-
-2	.156	.084	.156	.733	.853	-	-	-
-3	.219	.157	.219	.795	.916	.944	1.096	1.180
-4	.281	.220	.281	.858	.978	1.006	1.158	1.242
-5	.344	.282	.344	.920	1.041	1.069	1.221	1.304
-6	.406	.345	.406	.983	1.103	1.131	1.283	1.367
-7	.469	.407	.469	1.045	1.166	1.194	1.346	1.429
-8	.531	.470	.531	1.108	1.228	1.256	1.408	1.492
-9	.594	.532	.594	1.170	1.291	1.319	1.471	1.554
-10	.656	.595	.656	1.233	1.353	1.381	1.533	1.617
-11	.719	.657	.719	1.295	1.416	1.444	1.596	1.679
-12	.781	.720	.781	1.358	1.478	1.506	1.658	1.742
-13	.844	.782	.844	1.420	1.541	1.569	1.721	1.804
-14	.906	.845	.906	1.483	1.603	1.631	1.783	1.867
-15	.969	.907	.969	1.545	1.666	1.694	1.846	1.929
-16	1.031	.970	1.031	1.608	1.728	1.756	1.908	1.992
-17	1.094	1.032	1.094	-	1.791	1.819	1.971	2.054
-18	1.156	1.095	1.156	-	1.853	1.881	2.033	2.117
-19	1.219	1.157	1.219	-	1.916	1.944	2.096	2.179
-20	1.281	1.220	1.281	NOT AVAILABLE IN	1.978	2.006	2.158	2.242
-21	1.344	1.282	1.344	-5	2.041	2.069	2.221	2.304
-22	1.406	1.345	1.406	-	2.103	2.131	2.283	2.367
-23	1.469	1.407	1.469	-	2.166	2.194	2.346	2.429
-24	1.531	1.470	1.531	-	2.228	2.256	2.408	2.492
-25	1.594	1.532	1.594	-	2.291	2.319	2.471	2.554
-26	1.656	1.595	1.656	-	2.353	2.381	2.533	2.617
-27	1.719	1.657	1.719	-	2.416	2.444	2.596	2.679
-28	1.781	1.720	1.781	-	2.478	2.506	2.658	2.742
-29	1.844	1.782	1.844	-	2.541	2.569	2.721	2.804
-30	1.906	1.845	1.906	-	2.603	2.631	2.783	2.867
-31	1.969	1.907	1.969	-	2.666	2.694	2.846	2.929
-32	2.031	1.970	2.031	-	2.728	2.756	2.908	2.992

▲ "Ø" TOLERANCES: FOR -5 & -6 SIZES +.030/-.010; FOR -8 & -10 SIZES +.040/-.010; FOR -12 SIZE +.050/-.010.

U.S. PATENT NO. 3643544. FOREIGN PATENTS GRANTED AND PENDING.

Fairchild
 CODE IDENT. NO.
92215

MONOGRAM
 CODE IDENT. NO.
98524

APPROVED DATE
 01-21-81 ECN # 2110

REV. LETTER AND DATE
 "F" 06-29-06 ECN#3794

NOTICE: THIS DRAWING IS PART OF THE PROPRIETARY ARTICLE HEREIN DISCLOSED. OWNED BY MONOGRAM AEROSPACE FASTENERS. ANY PARTY BY ACCEPTING THIS DOCUMENT ASSUMES CUSTODY THEREOF AND AGREES: A. THE INFORMATION SET FORTH HEREIN IS GIVEN IN CONFIDENCE AND THIS DOCUMENT WILL NOT BE COPIED OR REPRODUCED IN WHOLE OR IN PART, NOR ITS CONTENTS REVEALED IN ANY MANNER TO ANY PERSON EXCEPT TO MEET THE PURPOSE FOR WHICH IT WAS DELIVERED. B. WITHOUT THE WRITTEN CONSENT OF MONOGRAM AEROSPACE FASTENERS, THIS DOCUMENT AND THE INFORMATION CONTAINED HEREIN UNDER NO CIRCUMSTANCES WILL BE USED IN THE MANUFACTURE OR REPRODUCTION OF THE ARTICLE DISCLOSED, AND DELIVERY OF THIS DOCUMENT SHALL NOT CONSTITUTE ANY RIGHT OR LICENSE TO DO SO.

TITLE
 VISU-LOK, FASTENER, BLIND INTERNALLY THREADED, EXTERNAL SLEEVE TITANIUM
 100° REDUCED FLUSH HEAD, SELF-LOCKING 75 KSI SHEAR, GROUND SHANK

STANDARD
PLT1080
SHEET 1 OF 2

PROCUREMENT SPEC. : ESCBB-9, CLASS 3.

MATERIAL : NUT & SCREW : 6AL-4V TITANIUM PER AMS 4928 OR AMS 4967.
 SLEEVE : CORROSION RESISTANT STEEL.

HEAT TREAT : NUT & SCREW : HEAT TREAT PER AMS-H-81200. MAX. HYDROGEN 125
 PPM. SLEEVE : AS REQUIRED FOR PERFORMANCE.

FINISH & LUBRICANT : NUT : DRY FILM LUBE PER MIL-PRF-46010 TYPE I OR EVERLUBE 812
 PER MIL-PRF-81329. CETYL ALCOHOL PER MIL-L-87132, OPTIONAL.

③ SLEEVE : PASSIVATE PER AMS-QQ-P-35. DRY FILM LUBE PER MIL-PRF-46010 TYPE I OR
 EVERLUBE 812 PER MIL-PRF-81329, WWM CARBO-WAX, PARAFFIN WAX, AND/OR CETYL
 ALCOHOL PER MIL-L-87132 AT MANUFACTURER'S OPTION.

SCREW : DRY FILM LUBE PER MIL-PRF-46010 TYPE I OR EVERLUBE 812 PER MIL-PRF-81329,
 WWM CARBO-WAX, PARAFFIN WAX AND/OR CETYL ALCOHOL PER MIL-L-87132.
 AT MANUFACTURER'S OPTION.

PART CODE & EXAMPLE : PLT1080() - 8 - 8

GRIP LENGTHS IN 1/16THS (SEE TABLE II).
 NOMINAL BODY DIAMETER IN 1/32NDS (SEE TABLE I).
 FINISH / LUBE CODE (SEE ESCBB-4)
 BASIC PART NUMBER, SELF LOCKING BLIND FASTENER.

- GENERAL NOTES :
- 1.) OUTSIDE DIAMETER OF HEAD OF SCREW AND OUTSIDE DIAMETER OF SLEEVE SHALL NOT BE GREATER THAN MAXIMUM "E" DIAMETER.
 - 2.) CONCENTRICITY OF NUT HEAD CONICAL SURFACE TO "D" DIAMETER SHALL BE WITHIN .005 T.I.R. (EXCEPT OVER INDENTS).
 - 3.) REMOVE ALL LOOSE OR HANGING BURRS.
 - ④ LOCKING FEATURE CONSISTS OF THREE (3) INDENTATIONS LOCATED 120° APART ON THE PERIPHERY OF THE NUT COMPONENT AND APPROXIMATELY .040 ABOVE THE INTERSECTION OF THE NUT NOSE ANGLE AND O.D. (MEAN GRIP OF FASTENER). SHANK DIA. IN AREA OF LOCKING INDENTS SHALL NOT EXCEED THE MAXIMUM "D" DIA. PLUS .001
 - ⑤ MANUFACTURER'S IDENTIFICATION: LETTER "N" DESIGNATES MONOGRAM AEROSPACE FASTENERS. LETTERS "VS" DESIGNATE VOI-SHAN.
 - 6.) HEAD MARKINGS ON NUT DEPRESSED .010 MAX.
 - ⑦ HALF-GRIP SIZES MAY BE ORDERED BY ADDING (.5) TO THE GRIP DASH NUMBER.
 EXAMPLE: PLT 1080-6-4.5 INDICATES A NOMINAL GRIP LENGTH OF 4.5 SIXTEENTHS = .281. THE GRIP RANGE FOR THESE HALF-GRIP SIZES WILL BE NOMINAL GRIP + .031/- .030. THE BASIC "G" DIMENSION WILL BE NOMINAL GRIP + .031 AND THE OVERALL SCREW LENGTH "L" DIMENSION MAY VARY AT MANUFACTURER'S OPTION.
 - 8.) THESE PARTS HAVE A CLOSE TOLERANCE (.0005 INCH) GROUND SHANK AND ARE INTENDED FOR UP TO .0035 INCH DIAMETRAL INTERFERENCE FIT APPLICATIONS.
 - ⑨ DISTORTION OF "D" DIAMETER SHALL NOT PREVENT INSERTION OF THE FASTENER INTO A RING GAGE OF LENGTH EQUAL TO ONE DIAMETER AND DIAMETER EQUAL TO MAXIMUM "D" + .001". FORCE FOR INSERTION SHALL NOT EXCEED FIVE (5) POUNDS.
 - 10.) DIMENSIONS ARE EXCLUSIVE OF LUBRICATION.
 - ⑩ DIMENSIONS "A", "A'" AND "H" ARE FOR ENGINEERING REFERENCE PURPOSES ONLY AND ARE NOT TO BE USED FOR INSPECTION PURPOSES. THESE DIMENSIONS ARE THEORETICAL VALUES DERIVED FROM "D", "S", "M", "W" AND HEAD ANGLE DIMENSIONS.
 - ⑫ STANDARD GRIP LENGTHS ARE SHOWN IN TABLE II, SHORTER OR LONGER GRIPS THAN THOSE LISTED MAY BE AVAILABLE AS SPECIALS. ON GRIP LENGTHS SHORTER THAN THOSE LISTED, THE BREAKOFF LIMITS AND PREVAILING TORQUES SHOWN IN TABLE I DO NOT APPLY.
 - ⑬ STANDARD FINISHES AND LUBRICANTS ARE SHOWN ABOVE. REFER TO SPECIFICATION ESCBB-4 FOR SPECIAL FINISHES AND/OR LUBRICANTS, IF REQUIRED.
 - ⑭ ALUMINUM "D" DIAMETER MAY BE INCREASED BY .0002 TO ALLOW FOR SOLID FILM OR ALUMINUM COATING APPLICATION.
- U.S. PATENT NO. 3643544. FOREIGN PATENTS GRANTED AND PENDING.

Fairchild
 CODE IDENT. NO.
92215

MONOGRAM
 CODE IDENT. NO.
98524

APPROVED DATE
 01-21-81 ECN # 2110

REV. LETTER AND DATE
 "F" 06-29-06 ECN#3794

NOTICE: THIS DRAWING IS PART OF THE PROPRIETARY ARTICLE HEREIN DISCLOSED. OWNED BY MONOGRAM AEROSPACE FASTENERS. ANY PARTY BY ACCEPTING THIS DOCUMENT ASSUMES CUSTODY THEREOF AND AGREES A. THE INFORMATION SET FORTH HEREIN IS GIVEN IN CONFIDENCE AND THIS DOCUMENT WILL NOT BE COPIED OR REPRODUCED IN WHOLE OR IN PART, NOR ITS CONTENTS REVEALED IN ANY MANNER TO ANY PERSON EXCEPT TO THE EXTENT NECESSARY FOR THE PURPOSE FOR WHICH IT WAS DELIVERED. B. WITHOUT THE WRITTEN CONSENT OF MONOGRAM AEROSPACE FASTENERS, THIS DOCUMENT AND THE INFORMATION CONTAINED HEREIN UNDER NO CIRCUMSTANCES WILL BE USED IN THE MANUFACTURE OR REPRODUCTION OF THE ARTICLE DISCLOSED, AND DELIVERY OF THIS DOCUMENT SHALL NOT CONSTITUTE ANY RIGHT OR LICENSE TO DO SO.

TITLE
 VISU-LOK, FASTENER, BLIND INTERNALLY THREADED, EXTERNAL SLEEVE TITANIUM
 100° REDUCED FLUSH HEAD, SELF-LOCKING 75 KSI SHEAR, GROUND SHANK

STANDARD
PLT1080
SHEET 2 OF 2