

Printed copies are for reference only.

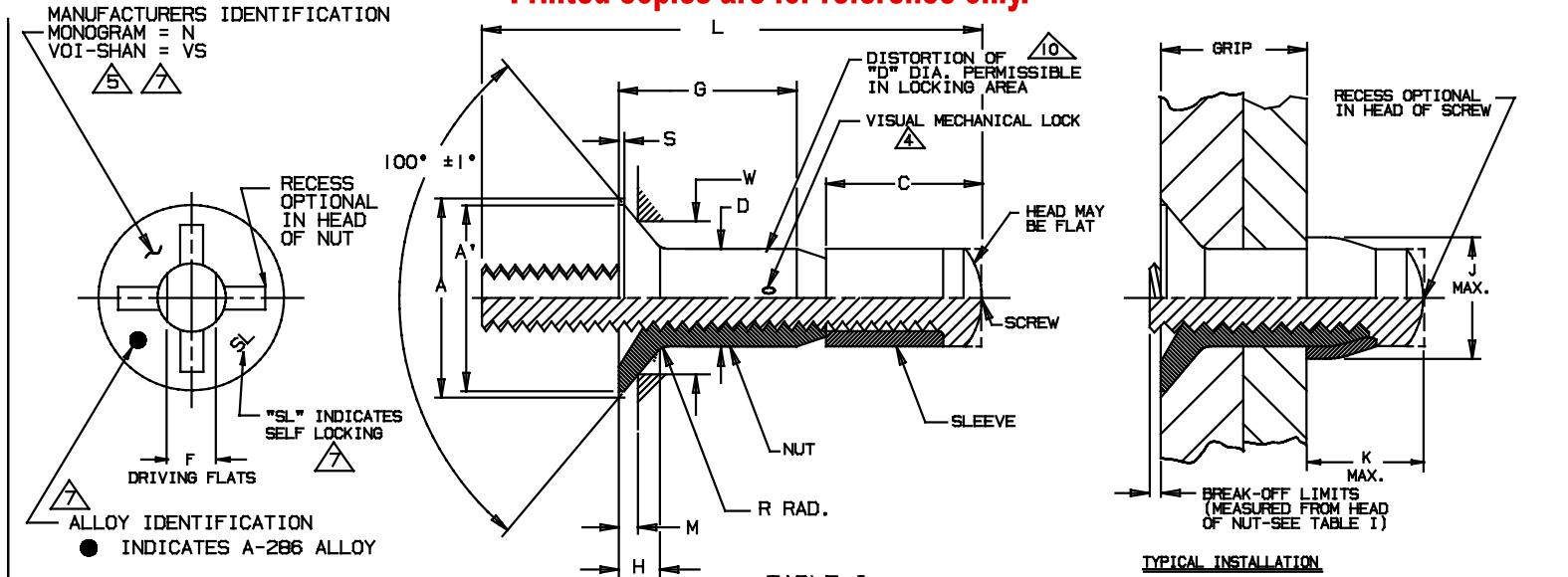

TABLE I

PART NUMBER	NOM. DIA.	A THEO. DIA.	A' DIA. MIN.	C MAX.	D DIA.	F DRIVING FLATS	H REF.	J DIA. MAX.	K MAX.	M GAGE PROT.	R RAD.	S MAX.	W GAGE DIA.	HOLE SIZE	BREAK-OFF LIMITS	PREVAILING TORQUE IN. LBS. MIN.	DOUBLE SHEAR STRENGTH LBS. MIN.	TENSILE STRENGTH LBS. MIN.
PLT 120-5-(*)	.1635	.332 .325	.296	.268	.1645 .1625	.086 .081	.069	.244	.246	.0276 .0238	.030 .010	.012	.2671 .2667	.168 .165	+0.082 -.006	1.0	3150	900
PLT 120-6-(*)	.1980	.395 .378	.342	.303	.1990 .1970	.104 .099	.077	.300	.281	.0299 .0259	.030 .015	.015	.3147 .3143	.202 .199	+0.072 -.016	1.5	4600	1400
PLT 120-8-(*)	.2590	.507 .499	.463	.354	.2600 .2580	.135 .130	.102	.384	.325	.0353 .0307	.030 .015	.015	.4245 .4241	.263 .260	+0.072 -.026	2.5	7900	2100
PLT 120-10-(*)	.3105	.635 .626	.577	.423	.3115 .3095	.152 .147	.134	.427	.390	.0409 .0357	.040 .020	.020	.5389 .5385	.315 .312	+0.072 -.031	3.5	11350	3600
PLT 120-12-(*)	.3735	.762 .752	.696	.510	.3745 .3725	.185 .180	.160	.516	.470	.0466 .0407	.040 .020	.023	.6532 .6528	.378 .375	+0.072 -.031	4.0	16450	5600

(*) SEE TABLE II FOR SECOND DASH NUMBER AND APPROVED CALLOUT.

TABLE II

SECOND DASH NUMBER	G GRIP	GRIP RANGE		L REF.					SECOND DASH NUMBER	G GRIP	GRIP RANGE		L REF.				
		MIN.	MAX.	PLT 120							MIN.	MAX.	PLT 120				
				-5-(*)	-6-(*)	-8-(*)	-10-(*)	-12-(*)					-5-(*)	-6-(*)	-8-(*)	-10-(*)	-12-(*)
-	-	-	-	-	-	-	-	-	-17	1.094	1.032	1.094	AVAILABLE	1.853	1.881	2.033	2.117
-2	.156	.094	.156	.795	.916	-	-	-	-18	1.156	1.095	1.156		1.916	1.944	2.096	2.179
-3	.219	.157	.219	.858	.978	1.006	1.158	-	-19	1.219	1.157	1.219		1.978	2.006	2.158	2.242
-4	.281	.220	.281	.920	1.041	1.069	1.221	1.304	-20	1.281	1.220	1.281		2.041	2.069	2.221	2.304
-5	.344	.282	.344	.983	1.103	1.131	1.283	1.367	-21	1.344	1.282	1.344		2.103	2.131	2.283	2.367
-6	.406	.345	.406	1.045	1.166	1.194	1.346	1.429	-22	1.406	1.345	1.406		2.166	2.194	2.346	2.429
-7	.469	.407	.469	1.108	1.228	1.256	1.408	1.492	-23	1.469	1.407	1.469		2.228	2.256	2.408	2.492
-8	.531	.470	.531	1.170	1.291	1.319	1.471	1.554	-24	1.531	1.470	1.531		2.291	2.319	2.471	2.554
-9	.594	.532	.594	1.233	1.353	1.381	1.533	1.617	-25	1.594	1.532	1.594		2.353	2.381	2.533	2.617
-10	.656	.595	.656	1.295	1.416	1.444	1.596	1.679	-26	1.656	1.595	1.656		2.416	2.444	2.596	2.679
-11	.719	.657	.719	1.358	1.478	1.506	1.658	1.742	-27	1.719	1.657	1.719		2.478	2.506	2.658	2.742
-12	.781	.720	.781	1.420	1.541	1.569	1.721	1.804	-28	1.781	1.720	1.781		2.541	2.569	2.721	2.804
-13	.844	.782	.844	1.483	1.603	1.631	1.783	1.867	-29	1.844	1.782	1.844		2.603	2.631	2.783	2.867
-14	.906	.845	.906	1.545	1.666	1.694	1.846	1.929	-30	1.906	1.845	1.906		2.666	2.694	2.846	2.929
-15	.969	.907	.969	1.608	1.728	1.756	1.908	1.992	-31	1.969	1.907	1.969		2.728	2.756	2.908	2.992
-16	1.031	.970	1.031	1.670	1.791	1.819	1.971	2.054	-32	2.031	1.970	2.031		2.791	2.819	2.971	3.054

Fairchild

CODE IDENT. NO.
 92215



G TOLERANCES: FOR -5 & -6 SIZES +.030/-.010; FOR -8 & -10 SIZES +.040/-.010; FOR -12 SIZE +.050/-.010.

U.S. PATENT NO. 3643544, OTHER PATENTS PENDING.

MONOGRAM

CODE IDENT. NO.
 98524

APPROVED DATE

13 NOVEMBER 1970

REV. LETTER AND DATE

ⓐ 03-28-94

NOTICE: THIS DRAWING IS PART OF THE PROPRIETARY ARTICLE HEREIN DISCLOSED, OWNED BY MONOGRAM AEROSPACE FASTENERS. ANY PARTY BY ACCEPTING THIS DOCUMENT ASSUMES CUSTODY THEREOF AND AGREES: A. THE INFORMATION SET FORTH HEREIN IS GIVEN IN CONFIDENCE AND THIS DOCUMENT WILL NOT BE COPIED OR REPRODUCED IN WHOLE OR IN PART, NOR ITS CONTENTS REVEALED IN ANY MANNER TO ANY PERSON EXCEPT TO MEET THE PURPOSE FOR WHICH IT WAS DELIVERED. B. WITHOUT THE WRITTEN CONSENT OF MONOGRAM AEROSPACE FASTENERS, THIS DOCUMENT AND THE INFORMATION CONTAINED HEREIN UNDER NO CIRCUMSTANCES WILL BE USED IN THE MANUFACTURE OR REPRODUCTION OF THE ARTICLE DISCLOSED, AND DELIVERY OF THIS DOCUMENT SHALL NOT CONSTITUTE ANY RIGHT OR LICENSE TO DO SO.

TITLE
 VISU-LOK, FASTENER, BLIND
 INTERNALLY THREADED, EXTERNAL SLEEVE
 HIGH TEMPERATURE (A-286 ALLOY)
 100° FLUSH HEAD, SELF LOCKING

STANDARD

PLT 120

SHEET 1 OF 2

PROCUREMENT SPEC. : ESCBB2 CLASS 2.

MATERIAL : NUT & SCREW CORROSION RESISTANT STEEL, TYPE A-286 PER AMS 5731, AMS 5732 OR
 SLEEVE : AMS 5737.

HEAT TREAT : NUT & SCREW SOLUTION HEAT TREATED AND AGED TO A HARDNESS OF Rc 30 TO Rc 45. ALL
 CORE HARDNESS READINGS ARE TAKEN ON MOUNTED SPECIMEN, USING A BRALE
 PENETRATOR A 30 Kg LOAD (ROCKWELL 30N).

SLEEVE : SOLUTION TREATED.

△ FINISH : NUT & SCREW
 SLEEVE : PASSIVATE PER MIL-S-5002 (QQ-P-35).

△ LUBRICANT: LUBRICANTS LISTED BELOW MAY BE APPLIED TO ANY OR ALL COMPONENTS IF REQUIRED FOR FASTENER PERFORMANCE:
 DRY FILM LUBE MoS₂ PER MIL-L-46010 TYPE I OR MIL-L-81329, WWM CARBO-WAX, PARAFFIN WAX AND/OR
 CETYL ALCOHOL PER MIL-L-87132.

PART CODE
 & EXAMPLE :

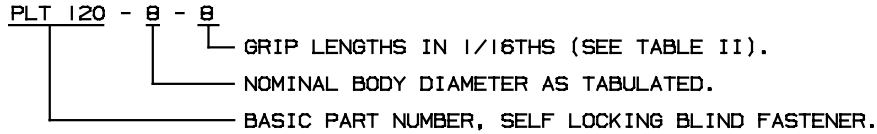

GENERAL NOTES :

- 1.) OUTSIDE DIAMETER OF HEAD OF SCREW AND OUTSIDE DIAMETER OF SLEEVE SHALL NOT BE GREATER THAN MAXIMUM "D" DIAMETER.
- 2.) CONCENTRICITY OF NUT HEAD CONICAL SURFACE TO "D" DIAMETER SHALL BE WITHIN .005 T.I.R., EXCEPT OVER INDENTATIONS.
- 3.) REMOVE ALL LOOSE OR HANGING BURRS.
- △ 4. LOCKING FEATURE CONSISTS OF THREE (3) INDENTATIONS LOCATED 120° APART ON THE PERIPHERY OF THE NUT COMPONENT AND APPROXIMATELY .040 ABOVE THE INTERSECTION OF THE NUT NOSE ANGLE AND O.D. (MEAN GRIP OF FASTENER).
- △ 5. MANUFACTURER'S IDENTIFICATION:
 LETTER "N" DESIGNATES MONOGRAM AEROSPACE FASTENERS.
 LETTERS "VS" DESIGNATE VOI-SHAN.
- 6.) HEAD MARKINGS ON NUT DEPRESSED .010 MAX.
- △ 7. THE PRODUCT DESCRIBED BY THIS DRAWING IS "EQUIVALENT TO" AND "INTERCHANGEABLE WITH" THE MANUFACTURER'S PRODUCT LISTED BELOW EXCEPT FOR COLOR IDENTIFICATION, HEAD MARKING AND SELF-LOCKING FEATURE. EXISTING STOCK MAY BE REWORKED TO COLOR AND HEAD MARKING MAY BE AS SHOWN BELOW:
 MONOGRAM... : FL164ALS-FL375ALS SERIES (MARKING: "N" AND "O" OVERSTAMPED "L" OR "SL").
 VOI-SHAN... : VA 402 SERIES (MARKING: "VS", "O" AND "SL").
- △ 8. STANDARD FINISHES AND LUBRICANTS ARE SHOWN ABOVE. REFER TO SPECIFICATION ESCBB-4 FOR SPECIAL FINISHES AND/OR LUBRICANTS, IF REQUIRED.
- △ 9. HALF-GRIP SIZES MAY BE ORDERED BY ADDING (.5) TO THE GRIP DASH NUMBERS.
 EXAMPLE: PLT 120-6-4.5 INDICATES A NOMINAL GRIP LENGTH OF 4.5 SIXTEENTHS = .281.
 THE GRIP RANGE FOR THESE HALF-GRIP SIZES WILL BE NOMINAL GRIP + .031/- .030.
 THE BASIC "G" DIMENSION WILL BE NOMINAL GRIP + .031 AND THE OVERALL SCREW LENGTH "L" DIMENSION MAY VARY AT MANUFACTURER'S OPTION.
- △ 10. DISTORTION OF "D" DIAMETER SHALL NOT PREVENT INSERTION OF THE FASTENER INTO A RING GAUGE OF LENGTH EQUAL TO ONE DIAMETER AND DIAMETER EQUAL TO MAXIMUM "D" + .001".
 FORCE FOR INSERTION SHALL NOT EXCEED FIVE (5) POUNDS
- △ 11. STANDARD GRIP LENGTHS ARE SHOWN IN TABLE II, SHORTER OR LONGER GRIPS THAN THOSE LISTED MAY BE AVAILABLE AS SPECIALS. ON GRIP LENGTHS SHORTER THAN THOSE LISTED, THE BREAKOFF LIMITS AND PREVAILING TORQUES SHOWN IN TABLE I DO NOT APPLY.
- △ 12. DIMENSIONS "A", "A'" AND "H" ARE FOR ENGINEERING REFERENCE PURPOSES ONLY AND ARE NOT TO BE USED FOR INSPECTION PURPOSES. THESE DIMENSIONS ARE THEORETICAL VALUES DERIVED FROM "D", "S", "V", "W" AND HEAD ANGLE DIMENSIONS.
13. DIMENSIONS ARE EXCLUSIVE OF LUBRICATION.

U.S. PATENT NO. 3643544, OTHER PATENTS PENDING.

Fairchild
 CODE IDENT. NO.
 92215

MONOGRAM
 CODE IDENT. NO.
 98524

APPROVED DATE
 13 NOVEMBER 1970

NOTICE: THIS DRAWING IS PART OF THE PROPRIETARY ARTICLE HEREIN DISCLOSED. OWNED BY MONOGRAM AEROSPACE FASTENERS. ANY PARTY BY ACCEPTING THIS DOCUMENT ASSUMES CUSTODY THEREOF AND AGREES:
 A. THE INFORMATION SET FORTH HEREIN IS GIVEN IN CONFIDENCE AND THIS DOCUMENT WILL NOT BE COPIED OR REPRODUCED IN WHOLE OR IN PART, NOR ITS CONTENTS REVEALED IN ANY MANNER TO ANY PERSON EXCEPT TO MEET THE PURPOSE FOR WHICH IT WAS DELIVERED.
 B. WITHOUT THE WRITTEN CONSENT OF MONOGRAM AEROSPACE FASTENERS, THIS DOCUMENT AND THE INFORMATION CONTAINED HEREIN UNDER NO CIRCUMSTANCES WILL BE USED IN THE MANUFACTURE OR REPRODUCTION OF THE ARTICLE DISCLOSED, AND DELIVERY OF THIS DOCUMENT SHALL NOT CONSTITUTE ANY RIGHT OR LICENSE TO DO SO.

TITLE
 VISU-LOK, FASTENER, BLIND
 INTERNALLY THREADED, EXTERNAL SLEEVE
 HIGH TEMPERATURE (A-286 ALLOY)
 100° FLUSH HEAD, SELF LOCKING

STANDARD
 PLT 120
 SHEET 2 OF 2

REV. LETTER AND DATE
 ① 03-28-94