

MONOGRAM AEROSPACE FASTENERS  
3423 SOUTH GARFIELD AVENUE  
LOS ANGELES, CALIFORNIA 90040



MONOGRAM  
AEROSPACE  
FASTENERS

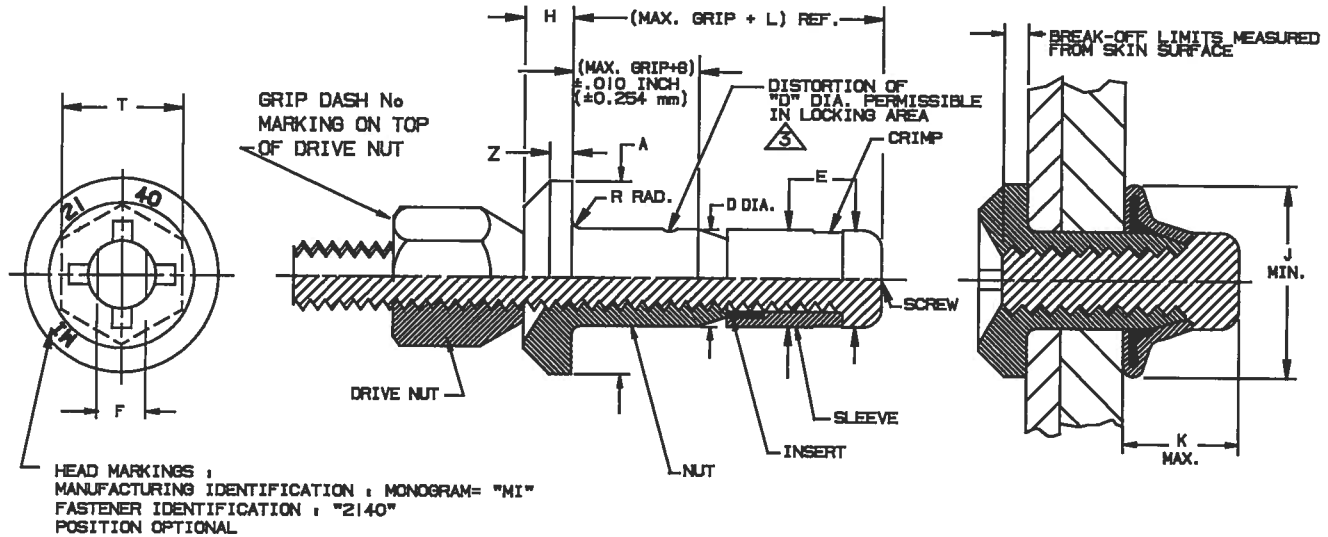

TABLE I

PART NUMBER	A DIA.		D DIA.		E DIA. MAX.		F WRENCH FLATS		G REF.		H		L REF.		R RAD. MAX.		T ACROSS HEX. REF.		Z MAX.				
	INCH	mm	INCH	mm	INCH	mm	INCH	mm	INCH	mm	INCH	mm	INCH	mm	INCH	mm	INCH	mm	INCH	mm			
MBF2140-05-()	.354 .334	8,99 8,48	.1645 .1625	4,178 4,128	.1640	4,166	.085 .080	2,16 2,03	.017	0,43	.060 .053	1,524 1,346	.512	13,00									
MBF2140-06-()	.416	10,57	.1985 .1965	5,042 4,991	.1985	5,042	.113 .108	2,87 2,74	.027	0,68	.070	1,778	.575	14,61					.030	0,762			
MBF2140-07-()	.396	10,06	.2275 .2255	5,778 5,728	.2275	5,778	.121 .116	3,07 2,95	.035	0,89	.063	1,600	.635	16,13	.030	0,76							
MBF2140-08-()	.541	13,74	.2595 .2575	6,591 6,541	.2595	6,591	.135 .130	3,43 3,30	.055	1,40	.085 .078	2,159 1,991	.700	17,78							.040	1,016	
MBF2140-09-()	.521	13,23	.2895 .2875	7,353 7,303	.2895	7,353	.152 .147	3,86 3,73	.065	1,65	.078	1,991	.815	20,70									
MBF2140-10-()	.635	16,13	.3115 .3095	7,912 7,861	.3110	7,899	.152 .147	3,86 3,73	.070	1,78	.105 .098	2,667 2,489	.892	22,66									
MBF2140-11-()	.615	15,62	.3435 .3415	8,725 8,674	.3433	8,720	.185 .180	4,70 4,57	.075	1,90	.098	2,489	.941	23,90	.040	1,02			.500	12,70		.045	1,143
MBF2140-12-()	.760 .740	19,30 18,80	.3745 .3725	9,512 9,462	.3740	9,500	.185 .180	4,70 4,57	.080	2,03	.125 .118	3,175 2,997	1.090	27,69									

TABLE I (CONT)

PART NUMBER	MINIMUM AVAILABLE GRIP LENGTH	INSTALLED DIMENSIONS								MECHANICAL PROPERTIES							
		RECOMMENDED HOLE SIZE		J DIA. MIN.		K MAX.		BREAK-OFF LIMITS		TENSILE STRUCTURAL FAILURE (MIN.)		DOUBLE SHEAR MIN.		LOCKING TORQUE MIN.			
		INCH	mm	INCH	mm	INCH	mm	INCH	mm	LBS.	N	LBS.	N	IN-LBS	Nm		
MBF2140-05-()	-100	.168 .165	4,27 4,19	.250	6,35	.300	7,62					900	4000	3150	14010	1.0	0,113
MBF2140-06-()		.202 .199	5,13 5,05	.300	7,62	.350	8,89					1400	6230	4600	20460	1.5	0,170
MBF2140-07-()		.231 .228	5,88 5,79	.350	8,89	.400	10,16					1600	7120	6050	26910	2.0	0,226
MBF2140-08-()		.263 .260	6,68 6,60	.400	10,16	.450	11,43	.+ .103 -.000		+2,62 -0,00		2100	9340	7900	35140	2.5	0,282
MBF2140-09-()		.283 .280	7,44 7,37	.450	11,43	.500	12,70					2600	11565	9800	43590	3.0	0,339
MBF2140-10-()		.315 .312	8,00 7,92	.475	12,06	.550	13,97					3600	16010	11350	50480	3.5	0,400
MBF2140-11-()		.347 .344	8,81 8,74	.525	13,33	.575	14,60					4400	19570	13850	61600	4.0	0,452
MBF2140-12-()		.378 .375	9,60 9,52	.575	14,60	.625	15,87					5000	22240	16450	73170	4.0	0,452

MONOGRAM

CODE IDENT. NO.  
98524

APPROVED DATE

11-23-11

NOTICE: THIS DRAWING IS PART OF THE PROPRIETARY ARTICLE HEREIN DISCLOSED, OWNED BY MONOGRAM AEROSPACE FASTENERS, ANY PARTY BY ACCEPTING THIS DOCUMENT ASSUMES CUSTODY THEREOF AND AGREES: A. THE INFORMATION SET FORTH HEREIN IS GIVEN IN CONFIDENCE AND THIS DOCUMENT WILL NOT BE COPIED OR REPRODUCED IN WHOLE OR IN PART; B. WITHOUT THE WRITTEN CONSENT OF MONOGRAM AEROSPACE FASTENERS, THIS DOCUMENT AND THE INFORMATION CONTAINED HEREIN UNDER NO CIRCUMSTANCES WILL BE USED IN THE MANUFACTURE OR REPRODUCTION OF THE ARTICLE DISCLOSED, AND DELIVERY OF THIS DOCUMENT SHALL NOT CONSTITUTE ANY RIGHT OR LICENSE TO DO SO.

REV. LETTER & DATE  
N/R ECN#5894  
11-23-11

TITLE

COMPOSI-LITE™ BLIND FASTENER  
LOW PROFILE PROTRUDING HEAD  
(TITANIUM NUT AND SCREW)

STANDARD

MBF 2140  
SHEET 1 OF 2

APPLICABLE SPECIFICATIONS:

PROCUREMENT SPECIFICATION:  
INSTALLATION & INSPECTION SPECIFICATION  
SPECIAL LUBE AND FINISH:  
PART NUMBER ASSIGNMENT:

MBF 2000.  
MBF 2003.  
MBF 2002.  
MBF 2004.

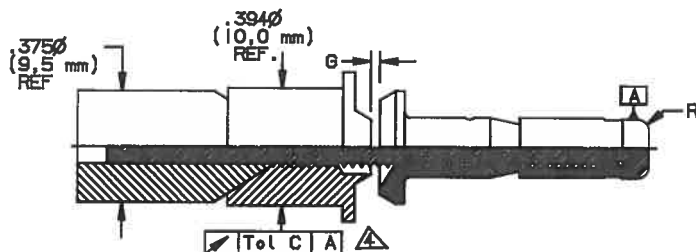

TABLE II  $\Delta$

ROBOTIC PART NUMBER	RADIUS R		MAX GAP G		MAX. CONC.		"Tol C" $\Delta$	
	INCH	mm	INCH	mm	GRIP <-500	GRIP >-500	GRIP <-1000	GRIP >-1000
MBF2140()-05-()A	.025 .010	0.635 0.254	.042	1.067	.030	0.762		
MBF2140()-06-()A	.030 .015	0.762 0.381	.050	1.270	.027	0.686	.030	0.762
MBF2140()-08-()A	.035 .020	0.889 0.508	.062	1.575	.022	0.559		

MATERIAL AND HEAT TREAT:

NUT AND SCREW: 6AL-4V TITANIUM PER MIL-T-9047 STA OR AMS4928 OR AMS4967 HEAT TREATED PER MIL-H-81200 TO 95 KSI SHEAR STRENGTH MINIMUM. MAXIMUM HYDROGEN CONTENT 125 PPM.

SLEEVE: 304 STAINLESS STEEL PER AMS 5639, FULLY ANNEALED.

INSERT: ACETAL PER ASTM D4181.

DRIVE NUT: MILD STEEL.

FINISH: (-) NUT: KAL-GARD ANN-RO #1012 CONVERSION COATING OR PHOSPHATE FLUORIDE PER MONOGRAM SPECIFICATION PS741, MAY BE USED AT MANUFACTURER'S OPTION.

SLEEVE: PASSIVATE PER AMS-QQ-P-35, KAL GARD ANN-RO #1013 CONVERSION COATING OPTIONAL.

INSERT: NONE.

DRIVE NUT: COLOR GRAY

LUBRICANTS: GRAPHITE FREE SOLID FILM LUBRICANT PER ASS272 OR MIL-PRF-81329 PARAFFIN WAX, OR CETYL ALCOHOL PER ASS7132. (AS REQUIRED FOR PERFORMANCE.) (SEE FINISH CODE FOR ADDITIONAL RESTRICTIONS)

TABLE III

2ND DASH NO. (GRIP)	GRIP RANGE			
	MIN. GRIP		MAX. GRIP	
	INCH	mm	INCH	mm
100	.050	1.27	.100	2.54
150	.100	2.54	.150	3.81
200	.150	3.81	.200	5.08
250	.200	5.08	.250	6.35
300	.250	6.35	.300	7.62
350	.300	7.62	.350	8.89
400	.350	8.89	.400	10.16
450	.400	10.16	.450	11.43
500	.450	11.43	.500	12.70
550	.500	12.70	.550	13.97
600	.550	13.97	.600	15.24
650	.600	15.24	.650	16.51
700	.650	16.51	.700	17.78
750	.700	17.78	.750	19.05
800	.750	19.05	.800	20.32
850	.800	20.32	.850	21.59
900	.850	21.59	.900	22.86
950	.900	22.86	.950	24.13
1000	.950	24.13	1.000	25.40
1050	1.000	25.40	1.050	26.67
1100	1.050	26.67	1.100	27.94
1150	1.100	27.94	1.150	29.21
1200	1.150	29.21	1.200	30.48
1250	1.200	30.48	1.250	31.75
1300	1.250	31.75	1.300	33.02
1350	1.300	33.02	1.350	34.29
1400	1.350	34.29	1.400	35.56
1450	1.400	35.56	1.450	36.83
1500	1.450	36.83	1.500	38.10
1550	1.500	38.10	1.550	39.37
1600	1.550	39.37	1.600	40.64
1650	1.600	40.64	1.650	41.91
1700	1.650	41.91	1.700	43.18

GENERAL NOTES:

1.) EXAMPLE OF PART NUMBER:

MBF 2140 ()-06 - 100 ()

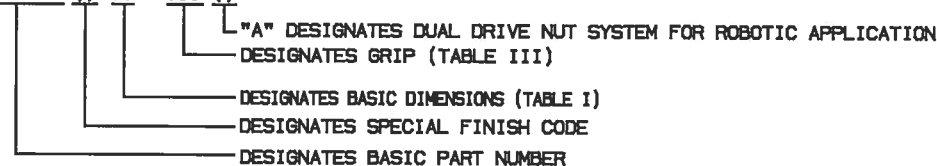

2.) LOCKING FEATURE CONSISTS OF THREE (3) INDENTATIONS LOCATED 120° APART ON THE PERIPHERY OF THE NUT COMPONENT AND APPROXIMATELY .040" ABOVE INTERSECTION OF THE NUT NOSE ANGLE AND O.D.

$\Delta$  DISTORTION SHALL NOT PREVENT INSERTION OF THE FASTENER INTO A RING GAUGE OF LENGTH EQUAL TO ONE DIAMETER AND HOLE DIAMETER EQUAL TO A MINIMUM RECOMMENDED HOLE. FORCE FOR INSERTION SHALL NOT EXCEED 5.0 POUNDS.

$\Delta$  MAXIMUM CONCENTRICITY (T.I.R) FROM DRIVE NUT TO SCREW HEAD WHEN DRIVE NUT IS FULLY SEATED (G=0) FOR GRIPS UNDER/EQUAL -1000. FOR GRIPS LONGER THAN -1000 "Tol C" TBD.

$\Delta$  ALL OTHER DIMENSIONS ARE THE SAME AS IN THE TABLE I.

6 STANDARD GRIP LENGTHS ARE SHOWN IN TABLE III. INTERMEDIATE GRIP LENGTH MAY BE AVAILABLE UPON REQUEST. EXAMPLE: 2ND DASH No. 225 SHALL HAVE MIN GRIP .125 (3.175mm) AND MAX GRIP .225 (5.715 mm)

MONOGRAM

CODE IDENT. NO.  
98524

APPROVED DATE

11-23-11

REV. LETTER & DATE

N/R ECN#5894

11-23-11

NOTICE: THIS DRAWING IS PART OF THE PROPRIETARY ARTICLES HEREIN DEVELOPED, OWNED BY MONOGRAM AEROSPACE FASTENERS. ANY PARTY BY ACCEPTING THIS DOCUMENT AGREES TO THE TERMS AND CONDITIONS. A. THE INFORMATION SET FORTH HEREIN IS GIVEN IN CONFIDENCE AND THIS DOCUMENT WILL NOT BE COPIED OR REPRODUCED IN WHOLE OR IN PART, NOR ITS CONTENTS REVEALED IN ANY MANNER TO ANY PERSON EXCEPT TO MEET THE PURPOSE FOR WHICH IT WAS DELIVERED. B. WITHOUT THE WRITTEN CONSENT OF MONOGRAM AEROSPACE FASTENERS, THIS DOCUMENT AND THE INFORMATION CONTAINED HEREIN UNDER NO CIRCUMSTANCES WILL BE USED IN THE MANUFACTURE OR REPRESENTATION OF THE ARTICLES DESCRIBED AND DELIVERY OF THIS DOCUMENT SHALL NOT CONSTITUTE ANY RIGHT OR LICENSE TO DO SO.

TITLE

COMPOSI-LITE™ BLIND FASTENER  
LOW PROFILE PROTRUDING HEAD  
(TITANIUM NUT AND SCREW)

STANDARD

MBF 2140

SHEET 2 OF 2